

Audio Regenesi

PC-4 Restoration Board



for Dynaco MK-IV

Thank you for choosing an Audio Regenesi s restoration board for your Dynaco tube amplifier.

This restoration board replaces the PC-4 circuit board in Dynaco MARK IV amplifiers.

Audio Regenesi s restoration boards are based upon the original Dynaco circuitry but employ modern high quality components, like fiberglass FR-4 circuit boards, metalized poly and silver mica capacitors, and low noise metal film resistors. The circuit board mounting holes and solder connection eyelets are located for complete compatibility with the original Dynaco circuit boards to ensure a quick and easy installation.

Installation is quite easy, however, it is assumed you possess basic soldering skills and equipment. It may be helpful to have a copy of the original Dynaco assembly manual to refer to when installing the Audio Regenesi s PC-4 board. If you require an assembly manual a free copy may be downloaded at:

www.audioregenesis.com/manuals



HIGH VOLTAGE WARNING

Vacuum tube amplifiers contain lethal voltages. Before beginning the installation of your new Audio Regenesi s board, make sure the power switch has been set to the OFF position and the power cord is disconnected from the 115V AC outlet. Wait 30 minutes before removing the top and bottom covers to allow the voltage on the power supply capacitors to bleed off.

PC-4 Installation

- Step 1:**
After allowing time for the power supply capacitors to discharge remove the top and bottom covers, as well as the tubes on the existing PC-4 circuit board.
- Step 2:**
Carefully unsolder and remove all the wires from the original Dynaco PC-4 circuit board. **Label each wire with the related eyelet number or connection point as you remove them.**
- Step 3:**
When all the wires are unsoldered and labeled remove the four screws that secure the original PC-4 board and remove the board. Note the orientation of the circuit board so that you install the new board in the same way.
- Step 4:**
Install the Audio Regenesi s PC-4 board using the screws that were removed in step 3.
- Step 5:**
Solder the wires (previously removed and labeled) to the related eyelets on the Audio Regenesi s PC-4 board.
- Step 6:**
Carefully check your wiring to be sure all wires are connected correctly.

Installation of the Audio Regenesi s PC-4 restoration board set is now complete. The tubes may now be re-installed, and the top and bottom covers installed. The amplifier is now ready to operate.

Be sure to adjust the bias potentiometer as described in the Owners Manual.

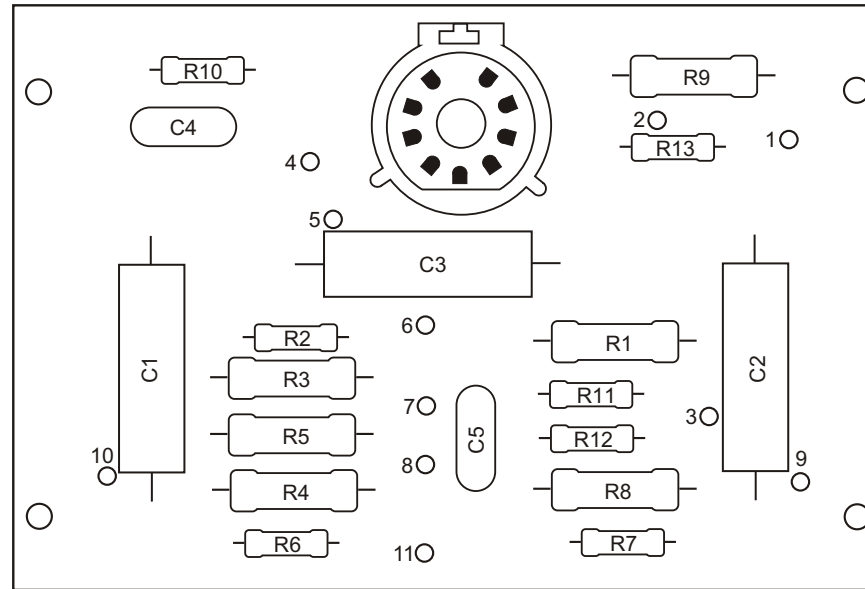

- | | | | |
|-----|---------------|----|------------|
| R1 | 330K 1W | C1 | 0.1uF 630V |
| R2 | 1.5M 0.5W | C2 | 0.1uF 630V |
| R3 | 270K 1W | C3 | 0.1uF 630V |
| R4 | 47K 1W | C4 | 82pF Mica |
| R5 | *47K 1W | C5 | 390pF Mica |
| R6 | *270K 0.5W | | |
| R7 | *270K 0.5W | | |
| R8 | 1K 1W | | |
| R9 | *47K 1W | | |
| R10 | 18K 0.5W | | |
| R11 | 620 ohm 0.5W | | |
| R12 | 47 ohm 0.5W | | |
| R13 | 470K ohm 0.5W | | |

* Matched 1%

Pacific Audio Regeneration

PC-4 Assembly

