

New 6GH8A Driver Tubes for the Super Seventy Amplifier

We have bad news and good news this month. The bad news is that the 7199 vacuum tube is discontinued and is no longer available except as residual old stock at a very high price. This tube was the heart of the Dyna St-70 amplifier and our Super Seventy upgrade thereto. It was a special design, a high voltage gain pentode first section and a high current gain triode second section, and it was supposed to be built to a low noise specification too. The only similar tube with the same pinout is the 6AN8A which is used in the Dyna MK III, but this tube is in short supply too and is not a viable long term replacement.

The good news is that Geoff Pomeroy, a consultant for John Peterson of Sound Values (Stereo Cost Cutters) has completed an extensive tube search and evaluation for Sound Values because they too need a replacement for the 7199 to keep their St-70 kits in production. Mr. Pomeroy notes that although there are many other nine pin pentode/triode tubes available, none are plug-in replacements for the 7199 because they all use different pinout configurations. He narrowed his evaluation to those tubes falling into just 2 pinout categories for the sake of broad replacement practicality. Then he evaluated the six tubes (6EA8, 6GH8, 6HL8, 6JW8, 6LM8, and 6U8) that all use the 9AE pinout because he was familiar with the performance, application use, and availability of some of this family. He actually ran distortion and open loop gain tests with these six tubes in a stock St-70 amplifier with the pinout changed to accommodate this tube family.

More good news is that the most available tube in this family, the 6GH8, actually provides lower closed loop harmonic distortion, lower noise, and higher open loop

gain across the frequency range than the 7199. Because it is widely used as a consumer television tube, it is available at a much lower price than the 7199. Interestingly enough, although it does not have a noise specification as does the 7199, the samples tested were actually significantly quieter. This is because the remaining dregs of 7199s simply didn't meet their noise specification. Mr. Pomeroy then experimented with reductions in the internal high frequency compensation of the stock St-70 circuit in the interest of further reducing distortion - but he discovered (as we knew) that doing so decreases the stability of the amplifier, a very undesirable trade-off.

John Peterson provided me with a copy of Mr. Pomeroy's very thorough report, and we proceeded to evaluate the use of the 6GH8A tube in the Super Seventy. We looked at the amplifier's internal error correction signals in addition to the output distortion, and the best news of all is that the 6GH8A makes the Super Seventy work much better than ever. The open loop linearity is significantly improved, the correction signals have a much more desirable shape, and the noise is as low as with the best "cherry picked" set of 7199s I still have. Because the tube has better drive capability in our circuit application, we were able make a low frequency compensation change that significantly improves bass linearity. The Super Seventy is a much clearer amplifier across the band with no negative trade-offs at all.

Thus we urge you to buy a set of 6GH8A tubes from Sound Value/Stereo Cost Cutters (I don't know their price - call them at 1-614-889-2117 to find out) and make the following circuit changes to your Super Seventy. If you are still running a stock old Dyna St-70 driver board I have included the diagram of the necessary foil cuts and jumper wires to convert that to 6GH8A use too.

PC Card Changes Required for Use of 6GH8A Tubes in Super Seventy & St-70

1. Note that once these changes have been made, 7199 tubes cannot be used, so get a set of 6GH8A tubes first. *Note that we are now supplying a pair of 6GH8A tubes in the Super Seventy rebuild kit at no extra cost and have already made the appropriate circuit board changes for you.* The kit, with 6GH8A tubes, is still \$150.00.
2. With the amp turned off, unplugged from AC, and cold, remove the top and bottom cover and the tube set keeping track of which sockets the output tubes were removed from.
3. Turn the amp upside down and locate the PC card foil for the Left and Right 7199 tube sockets as shown in the diagram on the next page.
4. With a Moto-Tool and a sharp burr tool, make the four foil cuts per channel as shown in the diagram. You will be isolating tube pins 2, 6, and 7 from the rest of the circuit.

indicated by the black dots. Keep the wires short, but not touching the foil except where soldered.

5. Install a jumper from pin 9 to pin 6.
 6. Install a jumper from pin 7 to the foil trace separated from pin 6.
 7. Install a jumper from pin 6 to the foil trace separated from pin 2 (outside of pin 2).
 8. Install a jumper from pin 2 to the foil trace separated from pin 7.
- Repeat for the other channel.
9. Remove C5 from each channel (.047 μ F/400V and replace each with a 0.33 μ F/250V or 400V capacitor (now supplied with the Super Seventy rebuild kit).

10. With a stock St-70 circuit board and either a stock or our modified circuit, make the same changes, referring instead to the diagram below.

11. Install the new 6GH8A tubes, install the power tubes back into the sockets they came out of, check the bias setting when you turn on the amp (it should not have changed) and enjoy a much more robust and dynamic amplifier.

Now you will install four short insulated jumper wires per channel. Solder them to the foil paths as

Frank Van Alstine

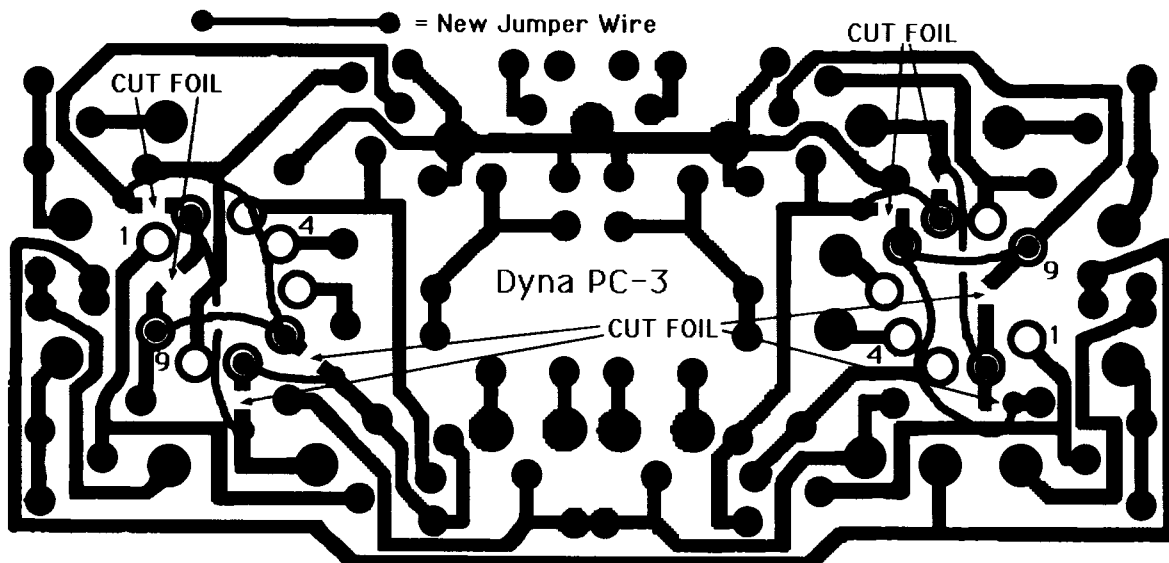

Foil Changes Necessary at tube sockets to convert Dyna St-70 PC-3 board for use with 6GH8A tubes instead of 7199 tubes. Four foil cuts and four jumper wires per channel are required. FVA 8/1/90

Note:
6GH8A tubes
MUST BE USED
 after these changes
 are made. 7199 tubes
 cannot be used
 because socket
 pinout has been
 changed.

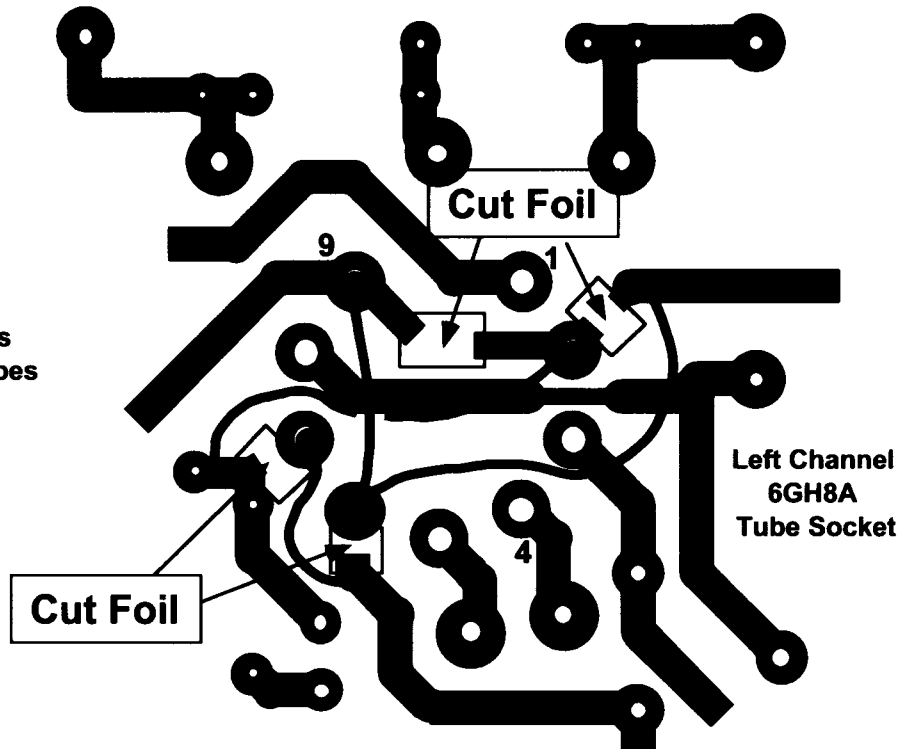

Foil Side View of AVA PC-189 Super Seventy Circuit Board
Diagram showing four foil cuts and four jumper wires needed per channel
to convert circuit board to use 6GH8A driver tubes instead of 7199 tubes
for higher performance and better future tube availability. 8/1/90 FVA

Note:
 For improved bass
 performance, change
 C5 on each channel
 from 0.047 μ F/400V to
 0.33 μ F/250V or 400V

